



C-HOOKS



C-HOOKS

P.W. Stalkomat Sp. z o.o. was established in 1992. Our company deals with designing and manufacturing technological transport devices, more known as ropes. We have a long-term experience in their production, because we are continuing the tradition of SOS SOSTAL from which we originate. Typical wire, chain, polyester or webbing sling ropes are manufactured according to PN-EN regulations and have the WLL and length according to customer's needs. We also produce lifting beams, metal tongs, plate tongs, metal sheet lifters, manhole housing lifters etc. We design and build according to our customers' individual needs on the basis of obligatory norms, endurance calculations and using the appropriate standards of Dyrektywa Maszynowa 2006/42/WE. Each rope or a group of equal ropes receives The Certificate of Quality or The Declaration of Conformity with obligatory norms and a CE mark. We also offer help in choosing ropes and in re-attestation and regeneration of used ropes. With our company- **YOU WORK WITHOUT RISK !!!**



C-HOOKS

C-HOOKS

C-HOOK WITH A CONSTANT HANDLE - USUALLY USED FOR ONE TYPE OF COILS

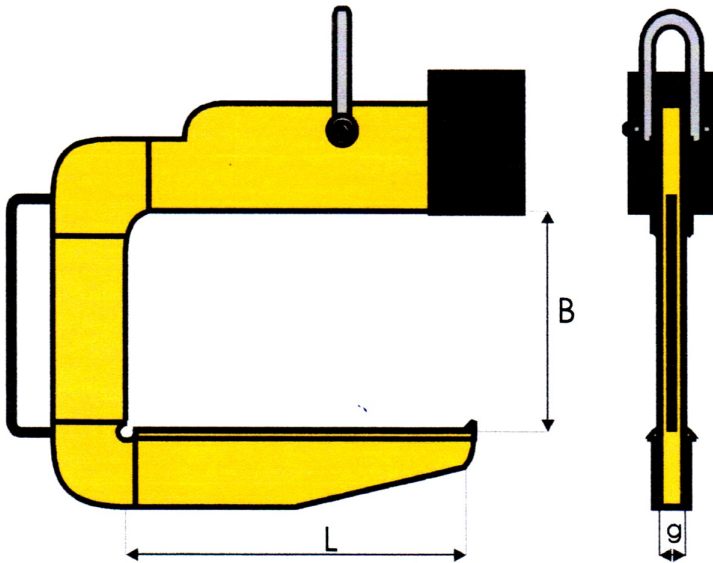

C-HOOKS

C-HOOKS

C-HOOK WITH A CONSTANT HANDLE USUALLY USED FOR ONE TYPE OF COILS (LOW WIDTH)

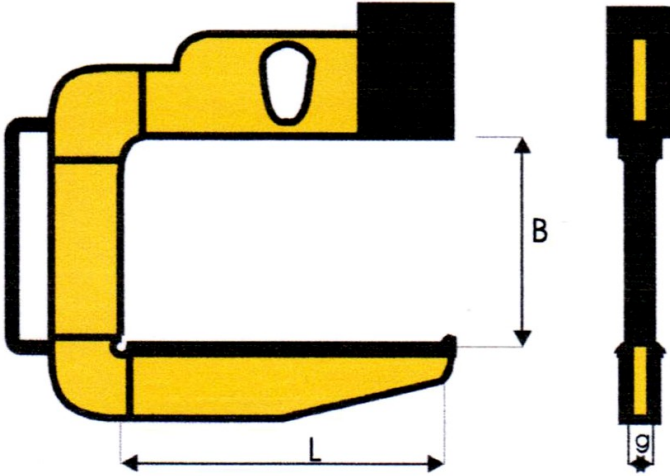

C-HOOKS

C-HOOKS

C-HOOK LIFTED ON A CHAIN ROPE USED FOR HIGH WIDTH
'L' COILS

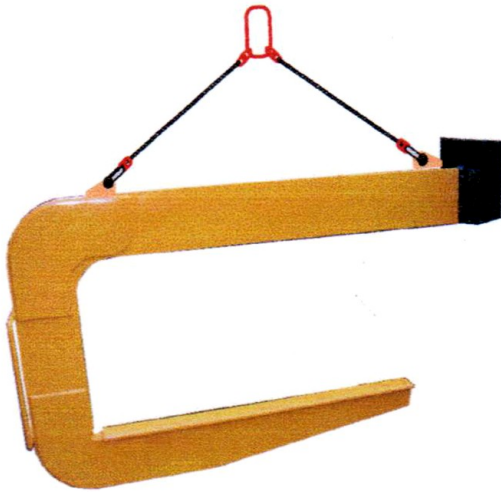
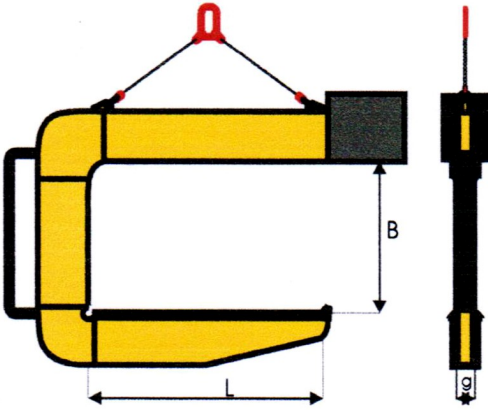

When ordering, please specify:

- *Working Load Limit WLL*
- *Beam's length 'L' - equal to coil's width or length*
- *C-hook's clearance „B” - higher at least 1/2 than thickness of the coil roll*

C-HOOKS

C-HOOKS

C-HOOK WITH MANUAL SETTING OF CENTRE OF GRAVITY

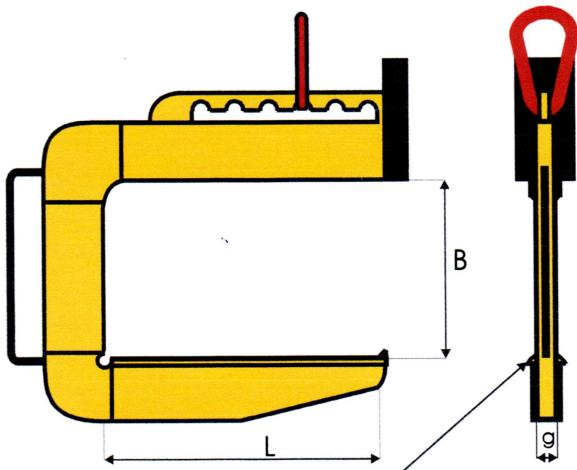

C-hook can be adjusted to coils of different width „L” as well as to transport a few coils simultaneously—L dimension can be up to 2250 mm

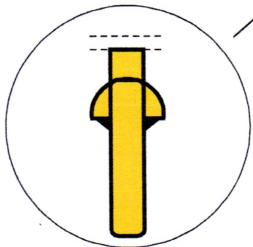

Using rounded edges can avoid deformations of transported material

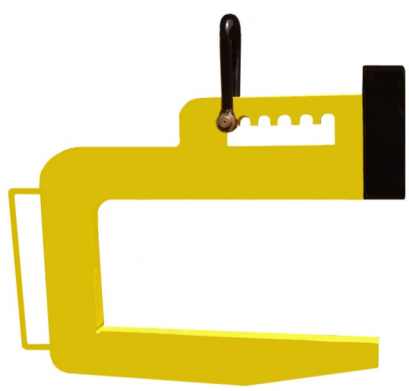

C-HOOKS

C-HOOKS



When ordering, please specify:

- *Working Load Limit WLL*
- *Beam's length 'L' - equal to coil's width or length*
- *C-hook's clearance „B” - higher at least 1/2 than thickness of the coil roll*

C-HOOKS

C-HOOKS

C-HOOK FOR A RAMSHORN WITH A RACK



*WLL and size can be adjusted
to customer's needs*

C-HOOKS

C-HOOKS

COIL TONG FOR RECOILER



*WLL and size can be adjusted
to customer's needs*

C-HOOKS

C-HOOKS

COIL TONG WITH A MOVABLE FOOTER

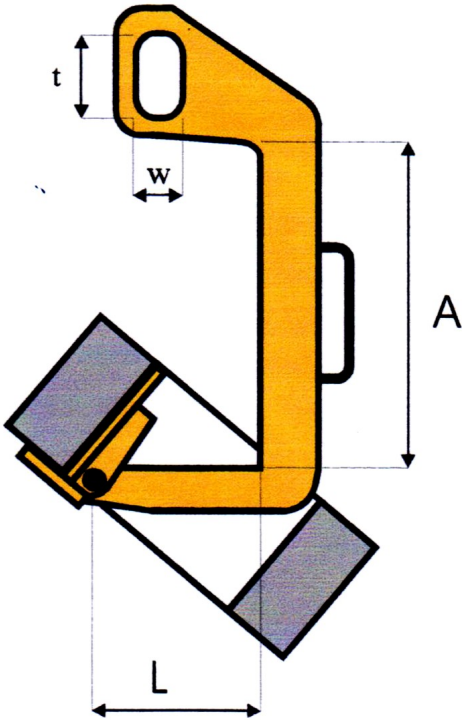

- When ordering, please specify:*
1. Working Load Limit WLL
 2. Coil size
 3. The number of hook on which the tong is going to operate

Such C-hooks are manufactured for maximum size of:

- „L“ = 300 mm*
- „A“ = 600 mm*
- „Q“ = 3,0 t*

Dimensions „t“ i „w“ depend on gantry's hook size

C-HOOKS

C-HOOKS

ADJUSTABLE STRETCHER SET FOR CARRYING COILS

The set of two C-hooks with an adjustable stretcher allows to transport coils of big weight. Adjustable stretcher makes it possible to use the device universally

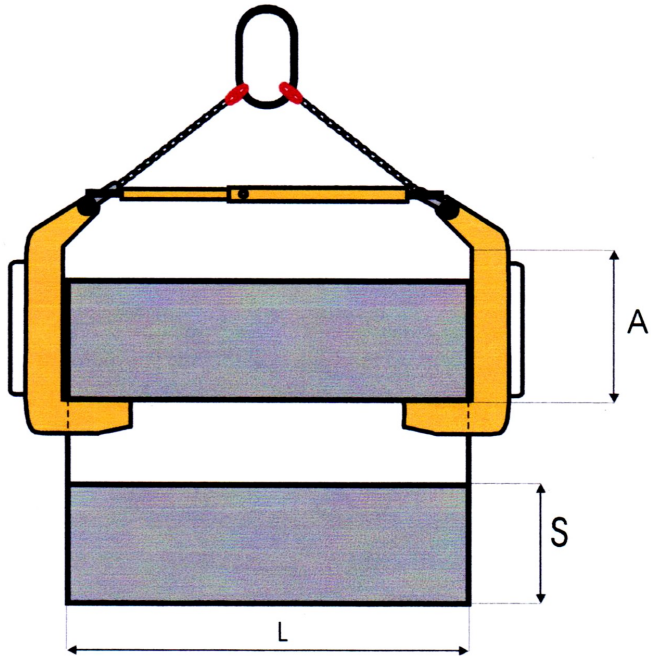

When ordering please specify:

- 1. Coil's weight*
- 2. Dimensions „L” and „S”*

C-HOOKS



P. W. Stalkomat Sp. z o.o.

Al. Mireckiego 22

41-200 Sosnowiec

NIP: 644-001-18-96

www.stalkomat.arg.pl

[e-mail: stalkomat@arg.pl](mailto:stalkomat@arg.pl)

Tel. (0-32) 785-52-33

Tel/fax (0-32) 299-64-21